



# **Dehumidifier User Manual**

**This manual is an integral part of the product and must be supplied to the installer and the end user.**

**The advice included in this manual must be carefully read as they supply important indications about safety and maintenance. Keep this manual in order to consult it if necessary.**

**The appliance must be installed according to the standards in force, by qualified personnel, this means by personnel having skills to care of these type of products and heating**

**installations.**

**A failing installation can cause damages to persons,  
pets or items.**

**Manufacturer shall not be held responsible for any  
failure to comply with safety and maintenance  
instructions set forth in the manual .**

**When unpacking the unit, check its state.**

**Before connecting the unit, make sure that the  
advice supplied by this manual are in accordance  
with the installation and its conditions of use.**

**IMPORTANT \* CAUTION \* IMPORTANT**

**Before any servicing, maintenance and repair, switch off the main supply.**

**In event of failure or abnormal operation, switch off the unit before any repair.**

**Any repair shall be performed by authorized service personnel with genuine spare parts. The use of non-genuine parts can be harmful to the unit and to the persons.**

**In order to ensure a long-lasting efficiency of the unit, it shall be maintained in accordance with the instructions included in this manual.**

**In event of sale or transfer of this unit to another user, make sure this manual is supplied as well.**

**This unit must be exclusively used for the use it was designed to. Any other use shall be considered as improper and hazardous.**

**In event of damages due either to an improper installation or use or if the instructions provided or the standards in force are improperly applied, all manufacturer's responsibilities will be avoided.**

# Content

I.	Please read immediately .....	1
II.	Delivery Conditions.....	2
III.	NF C15.100 Pool regulation .....	2
IV.	Voltage.....	3
V.	Application .....	3
VI.	Features.....	3
VII.	Description & Technical Parameters.....	4
VIII.	Overall Dimension.....	5
IX.	Installation Guide.....	6
X.	LCD Controller Operation .....	9
XI.	Test running .....	12
XII.	Precautions.....	12
XIII.	Repair and maintenance.....	13
XIV.	General Troubleshooting.....	14
XV.	Maintenance.....	14
XVI.	Recycling .....	15
XVII.	Fault display.....	15
	Appendix 1: Installation of Heating Element(Optional) .....	17
	Appendix 3: Explosive Diagram & PCB layout .....	22

## **I. Please read immediately**

### **Attention!**

- A. This machine is an ordinary Dehumidifier and can never be used for regulating other combustible gas and stale air.
- B. The main power switch should be installed out of the reach of children to avoid dangers caused by their playing with the switch.
- C. If it is necessary to remove the machine shell during repair and maintenance, please make sure that power has been cut off.

### **Notice for Use**

- A. The repair and maintenance must be conducted by certified professionals. The power supply circuit must comply with local standards and please read instructions carefully.
- B. Set appropriate humidity levels to create a comfortable environment.
- C. Dust gauze must be cleaned regularly.
- D. Please don't place objects close to the air inlet or outlet which may block the airflows.
- E. In case of a power failure during operation, the device will stop and shall start automatically after power restoration.
- F. Don't put hands, sticks or other objects into the air inlet and outlet. Don't dismantle the running fans of the dust gauze.
- G. If any abnormal situation appears, such as strange noises, smell, smoke, electric leakage, etc., please cut off electricity immediately and contact local dealer. Do not repair the machine by yourself.
- H. The usage or storage of hair gel, paint, oil or other combustible gas or liquid near the device is forbidden, otherwise there might be fires.

## II. Delivery Conditions

Every product can be harmed during transportation, even if well packed and issued, so the transporter should know about these risks that can occur during transport. A delivery list should be made, in which any damage made during transportation should be registered. (Confirmation by registered letter to the carrier within 48 hours).

## III. NF C15.100 Pool regulation

In volumes 0 and 1, only protective measure by TBTS (Article 411.1), with rated current less than 12V AC or 30V DC, is admitted, and being the source of Security outside the packages installed 0.1 and 2 (the unit has at least a degree of protection IP X5).

In volume 2 (see Figures 702A and 702B), the devices should be: - Class II, in the case of lighting,

- Class I and protected by a protective device for residual current, indicated or equal to 30 mA,

- Fed through an isolating transformer, according to the provisions of paragraph 413.5.1

The device has at least one degree of protection IP X2.

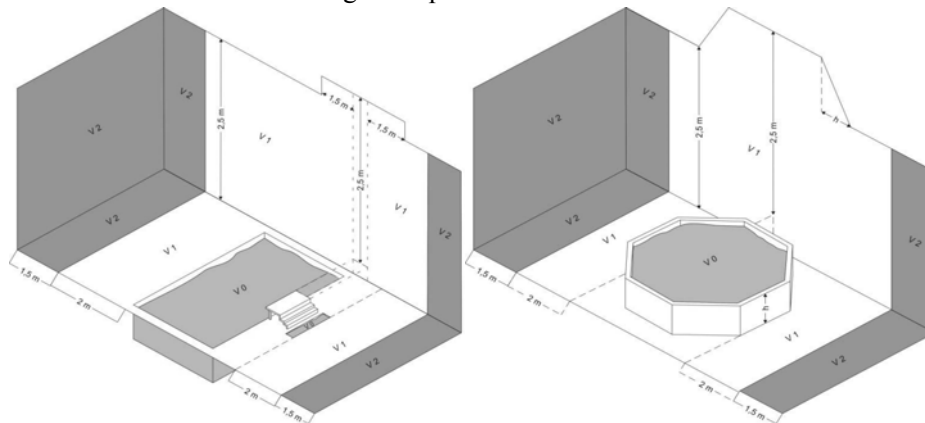

h: unknown variable v: volume

**Note:** Dimensions can be measured, considering walls and isolated interposed walls.

#### **IV. Voltage**

Before any operation made, the voltage should be checked: it must be the same that the one indicated on the product and the supply chain.

#### **V. Application**

1. Economically and efficiently dehumidification, providing you a cozy environment.
2. Users can decide an appropriate model by referring to the technical parameters and under the guidance of professional personnel.  
Dehumidifiers of this series have been adjusted to the best of its performance and they can work properly after wiring and connection of the drain hose by professionals under the standards.

#### **VI. Features**

1. Efficient heat exchanger.
2. Sensitive and accurate digital control of humidity.
3. Environmental friendly refrigerant R410A.
4. Built-in high-voltage, low-voltage and overheat protection system.
5. Ultra-low temperature automatic stop system.
6. Digital automatic defrosting.
7. High-quality compressor of world famous brands.
8. Easy installation and operation.



## VII. Description & Technical Parameters



Mode Ref.	FAI-150-0151	FAI-150-0012	FAI-150-0013
Operating Temperature (°C)	10~38	10~38	10~38
Capacity in (l/h) (Air 30°C, Humid 70%)	2.5	3.9	5.0
Heat Recovered (kW)	2.8	4.2	5.5
Rated Power (kW)	1	1.7	2
Rated Current (A)	4.58	7.83	9.15
Max Input Power (kW)	1.2	2.0	2.45
Max Input Current (A)	5.2	9.15	10.8
Power supply	220-240V/1Ph/50Hz		
Air flow (m <sup>3</sup> /h)	800	1000	1200
Electric Heating Optional (kw)	2.0	3.0	3.0
Net Dimension (mm)	855×242×848	1155×280×848	1155×280×848
Net Weight / Gross Weight (Kgs)	55/67	70/86	75/91

1. The rated current of electric heating is 8.7A for FAI-150-0151, 13A for FAI-150-0012 & FAI-150-0013.
2. Dehumidifying capacity refers to the dehumidifying volume when keeping the relative humidity at 30°C/70% .
3. Devices of this series can operate normally at the temperature of 10°C~38°C. Effects cannot be guaranteed if not within this range. Please notice under different working conditions, the technical parameters of the Dehumidifiers may vary.
4. Parameters are subject to modification without additional notice in case of technical upgrade. Please refer to the nameplate at the side of the machine for more information.

### VIII. Overall Dimension

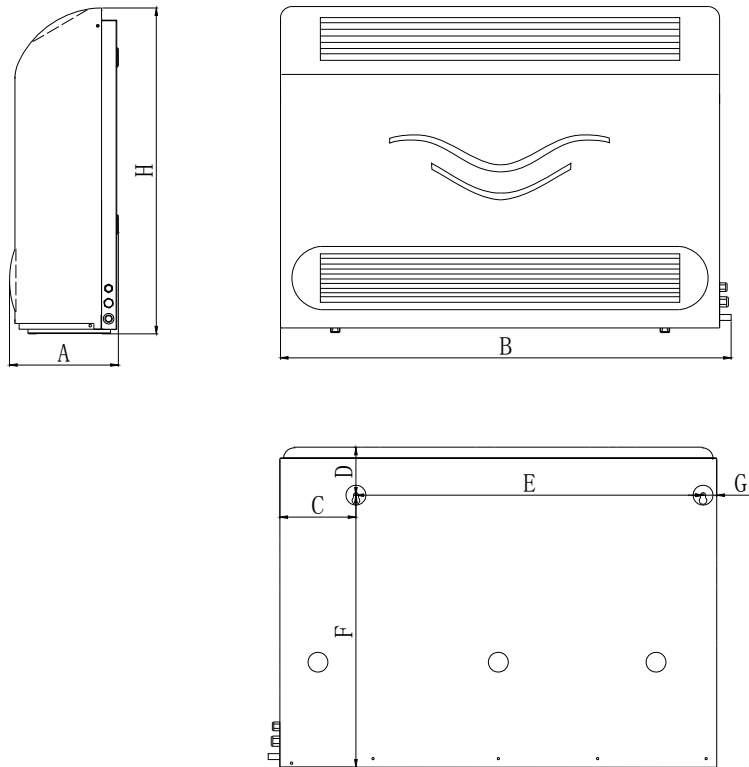

Size(mm) Name Model	A	B	C	D	E	F	G	H
FAI-150-0151	286	886	200	126	613	718	36	860
FAI-150-0012	286	1186	200	126	913	718	36	860
FAI-150-0013	286	1186	200	126	913	718	36	860

*Note: Above dimension is only for reference of professional workers during installation and arrangement. Due to the continuous improvements, the products will have phase adjustments without additional notices.*

## IX. Installation Guide

### 1. Position:

- 1) The distance of dehumidifier must be over 2 meters from the swimming pool. Distance may vary in each country, please verify your region legislation.

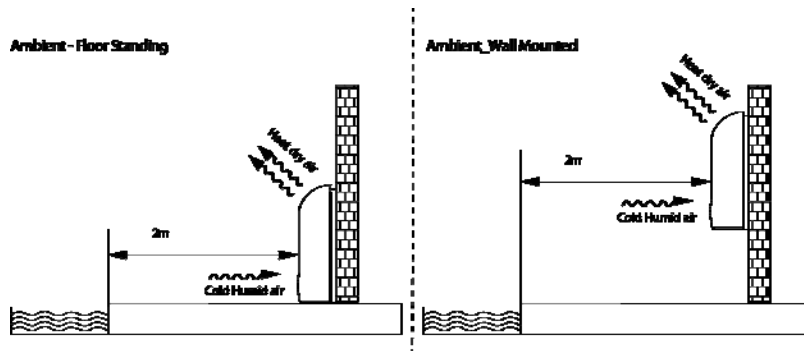

- 2) Make two holes in a solid wall and nail two explosion screws of  $\phi 12\text{mm}$ .
- 3) Hang the machine from the screws firmly through two circular holes at the back of the machine.
- 4) Connect drain hose.
- 5) Connect signal lines and power line in accordance with the connection diagram.

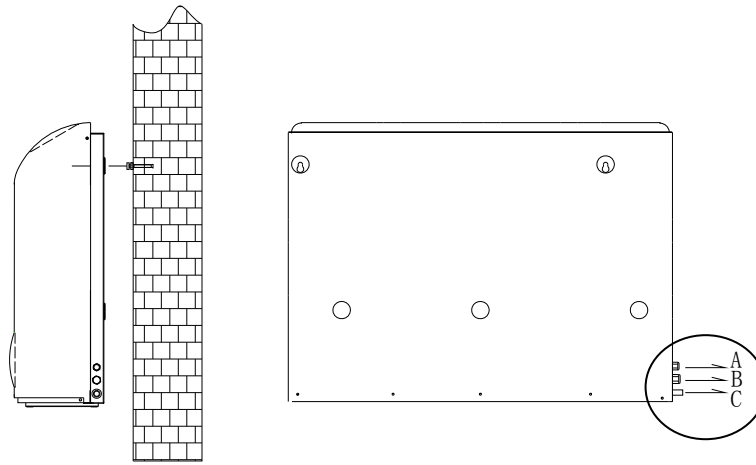

- A: signal line;
- B: power line;
- C: water outlet

**Note:** *The figure above is an example and the machine installation and arrangement is only for reference.*

## 2. Electrical wiring diagram

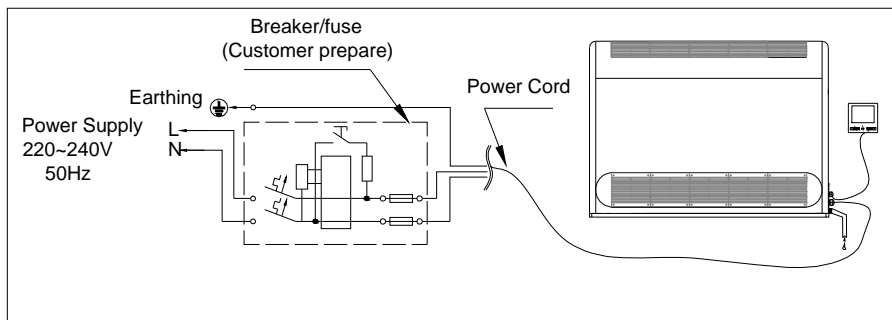

**Note:** *The Dehumidifier must have a good grounding.*

### 3. Selection of protective device and cable specification

Type		FAI-150-0151	FAI-150-0012	FAI-150-0013
Leakage circuit breaker	Rated current A	20	30	32
	Rated residual Operating current mA	30	30	30
Fuse A		20	30	32
Power cable (mm <sup>2</sup> )		3×2.5	3×4	3×4
Signal line (mm <sup>2</sup> )		3×0.5	3×0.5	3×0.5

*Note: The data above is suitable for power lines shorter than 10 meters. For those longer than 10 meters, the wire diameters must be increased. The maximum length of signal line is 50 meters.*

### 4. Installation instructions and requirements

Dehumidifier must be installed by professional technicians and please do not install it by yourselves, otherwise it may cause harm to people or damage the machine.

#### A. Installation of machine

- 1) Dehumidifier should be installed in a place with good ventilation.
- 2) The bolt (M 12) must be used to fix the machine body during the installation. The machine can be fixed on the concrete foundation or support, with the concrete foundation being firm and the support being of great strength and anti-rust treatment.
- 3) Please notice that there will be condensate water coming out from classis during the operation. Connect the drain port to the drainage hole in classis and link the drainpipe to enable the smooth flowing-out of condensate water.

## B. Electrical wiring installation

- 1) The supply voltage should be in line with the rated voltage of this product.
  - 2) The Dehumidifier must have a good grounding.
  - 3) Wiring must be conducted by professional technicians in accordance with the standards of circuit diagram.
  - 4) According to related technical standards for electrical equipment set by local region or country, the electric leakage protection device must be well set (residual operating current should be less than 30 mA).
  - 5) Power line and signal line arrangement should be tidy and reasonable without any interference. Depending on environmental conditions (environmental temperature, direct sunlight, rainwater, grid voltage, cable length, etc.), the sectional area can be increased.
- C. When the wiring construction is finished, the power can be on if there are no faults after careful checking.

## X. LCD Controller Operation

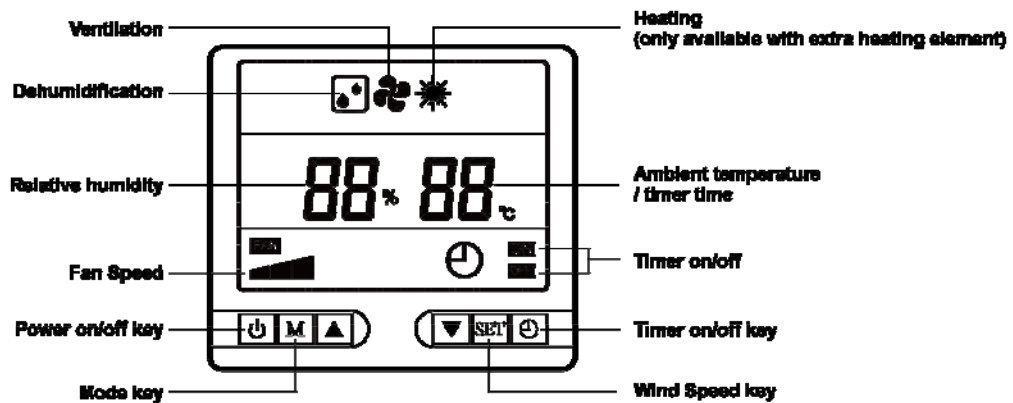

## 1. Display:

- a. The screen will display actual relative humidity (%) and ambient temperature (°C) when the machine is off.
- b. The screen will display following message when the machine is on.
  1. Mode;
  2. Actual relative humidity(%) and ambient temperature(°C);
  - 3.Fan speed and timer if set.

## 2. Setting:

### a. Mode setting

When the machine is on, press M key to switch the mode:

Dehumidifying mode: 

Ventilation mode: 

Heating mode:  (only available with extra heating element)



Dehumidifying and Heating: 

### b. Set Humidity (setting range: 30%—99%)

In the dehumidifying mode  no matter machine's on or off, every time you press button “▲” or “▼”, the set humidity will be increased or decreased by 1%. It'll flash for 8 seconds and then display the actual humidity again.

To check the set humidity, press ▲ or ▼ key under dehumidifying mode..

### c. Set Fan Speed:

When the machine' s on and in ventilation mode , press “SET” to switch the speed from High speed  and low speed .



**d. Timer Setting:**

① **Set timer**

When the device is on, the off time can only be set as 1~12H. When the machine is off, the on time can only be set as 1~12H.

Press button “

② **Cancel the timer**



Press  to have the time value flashing, then press button “



**e. Keypad lock setting**

Press “





keypad lock .

**f. Set Heating ( only available with extra heating element, the setting range is from 18°C to 32°C.)**

Under heating mode , every time you press  or , the set temperature can be increased or decreased by 1°C.

To check the set temperature, press  or  and it'll display the set temperature.

**g. Set Humidity& Heating ( only available with extra heating)**

Under mode dehumidifying and heating  , press  or  to reach the set humidity & temperature. Press “

11



## **XI. Test running**

1. Before usage
  - A、 Check whether the whole machine is place on the ground vertically and be connected with drain hose.
  - B、 Check whether the electrical wiring has been connected in accordance with the electrical wiring diagram and whether the earth wire has been linked reliably.
  - C、 Check whether the power of machine has been cut off.
  - D、 Check whether the set humidity is appropriate.
  - E、 Ensure the air inlet and outlet of the Dehumidifier haven't been blocked.
2. Test run
  - A、 Users should first switch on the power.
  - B、 As a protection, the device has the start delay function. Fan will start one minute before compressor.
  - C、 After the dehumidifier starts, check whether there is any strange noise during operation.

## **XII. Precautions**

1. Notes:
  - A、 Please don't place any object close to the air inlet or outlet which may block the airflows. Otherwise, the efficiency may be reduced or the whole operation of the system may even stop.
  - B、 Do not put hands, sticks or other objects into the air outlet of Dehumidifier or try to dismantle the grid during operation, or the fan running at a high speed may cause harm to people.
  - C、 If any abnormal situation appears, such as strange noises, smell, smoke, electric leakage, etc., please cut off electricity immediately and contact local dealers. Do not try to repair the machine by yourself.
  - D、 The usage or storage of hair gel, paint, oil or other combustible gas or liquid near the device is forbidden, otherwise there might be fires.
  - E、 Rinsing the machine directly with water is forbidden.

- F、 Please do not stand on or lean against the machine.
- G、 Please do not use it to preserve the artworks or academic materials or for other special purposes, otherwise the quality of restored objects could not be guaranteed.
- H、 This machine is only for indoor use. Please do not use it under the conditions with direct sunlight or wind and rain.

## 2. Safety rules

- A、 The main power switch should be installed out of the reach of children to avoid dangers caused by their playing with the switch.
- B、 If the electricity fails during the usage, this Dehumidifier will start automatically after the power restoration. Therefore, please switch off this machine. Otherwise there might be some accidents.
- C、 Please cut off the main power in thunderstorm weather, or else the lightning may damage the machine.
- D、 Please cut off the main power and drain water out of the machine if it is not used for a long time.

## **XIII. Repair and maintenance**

- 1、 Before working on the Dehumidifier, please make sure it is disconnected from the power supply.
- 2、 In seasons when this device is not used, please cut off its power and cover the machine body with plastic cloth so as to avoid the dust.
- 3、 When cleaning the machine, the domestic neutral detergent on a slightly damp cloth is recommended, please do not use volatile oil, gasoline, diluent agent or polishing power for cleaning.
- 4、 Annual check on bolts and cables is recommended, to see if the bolts have gone loosen, if the wires have been worn out or if the connections are firm.

#### XIV. General Troubleshooting

fault	Cause	Handling method
<b>Not operating</b>	Power cut	Waiting for power restoration
	Power switch not on	Switch on the power
	Fuse burnt out	Check the problem and replace the fuse
	Leakage circuit breaker being off	Check the problem and switch on the leakage circuit breaker
<b>Not Dehumidifying</b>	It's in defrost cycle	Wait to end the defrost cycle and verify if the pool environment temperature isn't below 10°C
	The indicated temperature of the plummet isn't between 10°C and 40°C	Verify if the plummet is well put. Regulate the temperature between 10°C and 40°C
If the problems above cannot be solved, please contact professional workers and inform them of the product type and details about faults.		

***Attention! Never dismantle the machine and repair it by yourself so as to avoid any danger.***

#### XV. Maintenance

**Monthly:** Check and clean the filter if necessary. To do so, wash it with water and soap, rinse and dry. If necessary change the filter.

**Annually:** Regulating and controlling the operation of each control device (thermostat-humidistat or hydro) if necessary vacuuming the interior of the latter. Clean the unit with a embed cloth. Check the cleanliness of the reservoir and the outlet pipe of the condensate. To improve the functioning of the device, can be

performed a visual inspection of the state of obstruction batteries (evaporator / condenser and hot water) disassembling the lid (off).

Depending on the state, effective cleaning with the help of a brush on silk and a vacuum cleaner

## XVI. Recycling

In accordance with the European Directive 2002/96/EC, and in order to reach a number of environmental protection objectives, the following rules must be obeyed.



These objectives apply to waste from electrical and electronic equipment (DEEE).

Consumers must return the used products to the collection points provided.

By enabling the products to be recycled, consumers contribute to the protection of our environment.

## XVII. Fault display

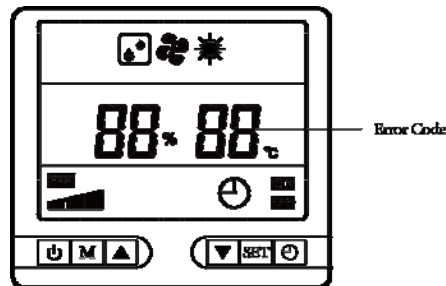

No	Error Code	Diagnosis	Solution
1	E1	Room temperature sensor failure	1.Check if terminal "SEN6" on the PCB got Loosen 2.Replace corresponding sensor

2	E2	Coil temperature sensor failure	1. Check if terminal “SEN5” on the PCB got Loosen 2. Replace corresponding sensor
3	E3	Humidity sensor failure	1. Check if terminal “H-SEN” on the PCB got loosen 2. Replace corresponding sensor
4	EF	Outlet temperature sensor failure	1. Check if terminal “SEN2” on the PCB got Loosen 2. Replace corresponding sensor
5	EH	Return gas temperature sensor failure	1. Check if terminal “SEN1” on the PCB got Loosen 2. Replace corresponding sensor
6	E4	High-Pressure protection	1. Check if any object stacking at inlet 2. Check if dust filters gets dirty, if yes, clean the filter; 3. Check if it's fan motor or fan capacitor defect, if yes, replace the part 4. Check if high pressure is around 2.8~3.2Mpa when at dry bulb 30C, wet bulb 26C. If it's higher than that, please check if any stuck in refrigerant system. If pressure normal, please check if any defect on high pressure switch
7	E5	Low-Pressure protection	1. Check if low pressure normal. If low pressure is around 1.0~1.2Mpa at dry bulb 30C, wet bulb 26C. That's normal. if not, please check if any leak. Repair the leak and recharge gas. 2. If it's normal, please check if any defect on low pressure switch
8	E7	Air outlet overheat protection	1. Check if any object stacking at inlet 2. Check if filters gets dirty 3. Check if it's fan motor or fan capacitor defect, if yes, replace the part
9	EE	Communication failure	1. Check if connection between PCB and LCD gets loosen. 2. Check if defect on signal wire, if yes please replace it. 3. Replace PCB or LCD
10	EC	Over heat protection (for product with additional heater )	1. Check if any object sucking at inlet 2. Check if filters gets dirty 3. Check if it's fan motor or fan capacitor defect, if yes, replace the part 4. Check if electrical heater over heat protection button tripped. if yes, press the button.

## Appendix 1: Installation of Heating Element(Optional)

Warning : The heating element of dehumidifier must be installed by qualified electrician.

### A. Component List :

1) Heating Element 1 pc

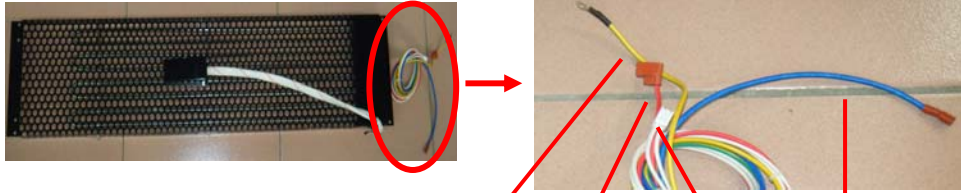

2) Screws 4 pcs



### B. Steps

- 1、 Make sure power supply is cut off before working on the unit. Dismantle the front panel from the unit.
- 2、 Place the heating element as shown below:

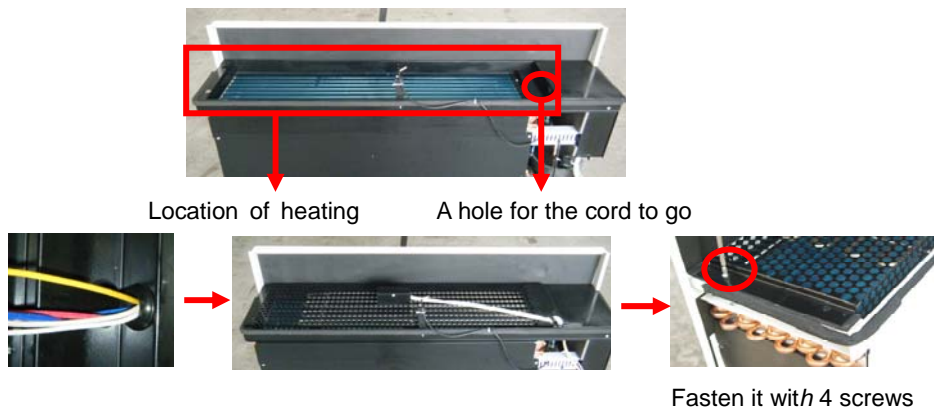

### 3、 Wiring of Signal Cable & Power Cable

#### A、 Wiring Signal Cable:

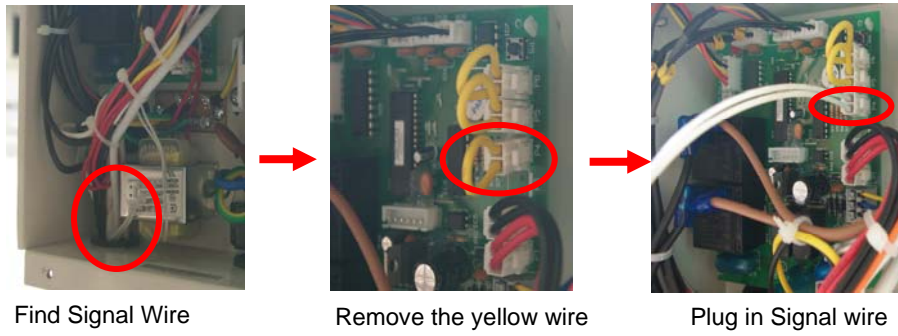
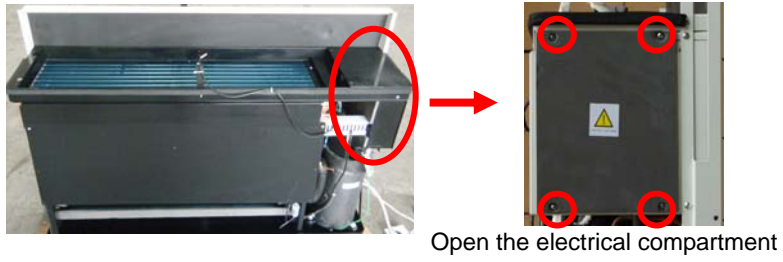

#### B、 Wiring Power Cable :

Please refer to the diagram below for connecting power cable. ( “L” port can be found on PCB )

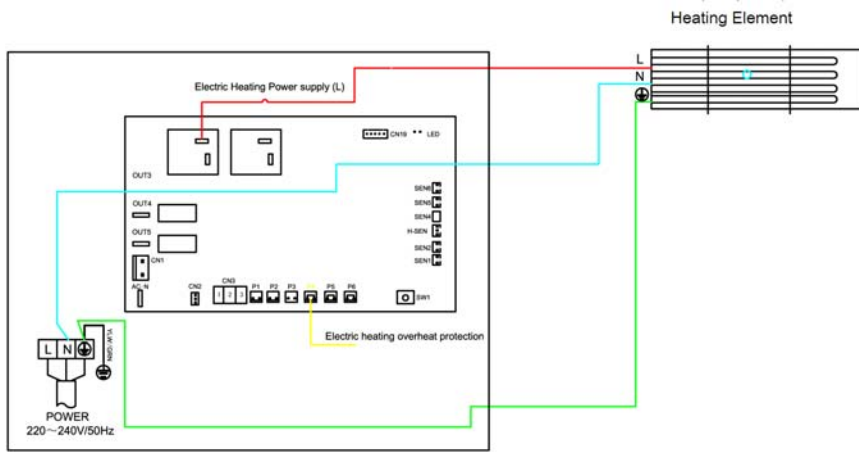

4、 Re assemble the front panel of the dehumidifier, fasten the panel by using screws on both sides

Upon completion of installation, please reset inner parameter “C1” to 1  
(Default value :0)



## Appendix 2: Inner Parameter Setting

Enter inner parameter setting interface by pressing “SET” for 3 seconds

**Warning:**

**Non-professional is not recommended to avoid error by incorrect operation.**

Fasten it with 4 screws

### Inner parameter's checking & setting:

Press button “SET” for three seconds and enter the menu of parameter checking & setting.

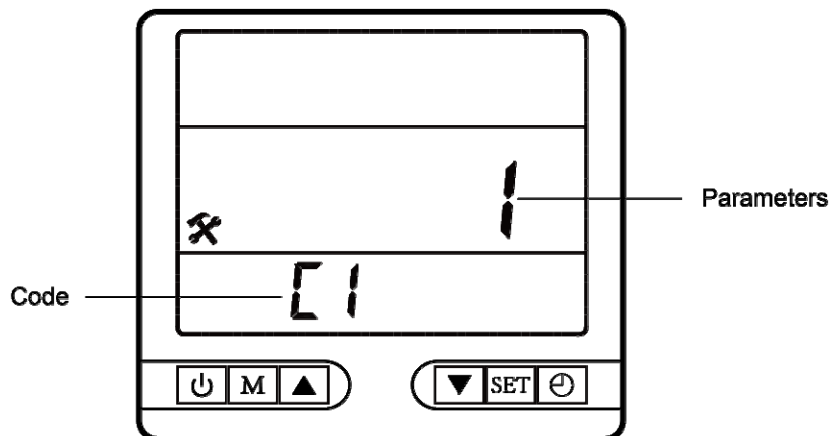

#### A. To check the inner parameters:

When machine' s on, press button “Set” for 3 seconds. And then press button “▲” and “▼” to check the code and relative parameter.

#### B. To set the inner parameters:

When machine' s off, press button “Set” for 3 seconds; Press “▲” and “▼” to check each code & parameter, press “Set” and the code will flash, you can press “▲”and“▼” to reset the parameter value. After, press “Set” to confirm. And press “⏻” or “⏹” to exit.

The parameter table is as follows:

NO.	code	Parameter meaning	Parameter specification	Default value
1	C1	Heating or not	0 no/1 yes	0
2	C2	Coil temperature	-20°C~99°C	Measured value
3	C3	Humidity compensation	-5% ~ 5%	0%
4	C4	Defrosting cycle	15Min~90Min	20Min
5	C5	Defrosting starting temperature	-10°C~10°C	-1°C
6	C6	Defrosting closing temperature	0°C~15°C	8°C
7	C7	Maximum defrosting time	2Min~12Min	12Min
8	C8	Working state of draught fan	0 reaching the set value and the fan stops/ 1 reaching the set value and the fan operates with low wind	1
9	C9	Air outlet temperature	-20°C~99°C	Measured value
10	CA	Return gas temperature	-20°C~99°C	Measured value
11	Cb	EXV step number	100~500P	Measured value
12	CC	Target superheat degree	-20°C~20°C	5°C

## Appendix 3: Explosive Diagram & PCB layout

### a. Explosive Diagram

		<b>FAI-150-0151</b>	<b>FAI-150-0012</b>	<b>FAI-150-0013</b>
1	Inlet Grid	003060010201-R	003060010201-R	003060010201-R
2	Filter and Filter Bracket	002060030998-R	003991200000-R	003991200000-R
3	Front Panel	003060030101	003060010101	003060010101
4	Vibration absorber	004990050000	004990050000	004990050000
5	Outlet Grid	003060010201-R	003060010201-R	003060010201-R
6	Front Seal Panel	002060030500	002060021700	002060021700
7	Temperature Sensor	035010010000-R	035010010000-R	035010010000-R
8	Right Centrifugal Fan	007020040200	007020040200	007020040200
9	Fan Motor	032020500000	032020850000	032020850000
10	Left Centrifugal Fan	/	007020040100	007020040100
11	Controller	034060010000	034060010000	034060010000
12	High / Low Pressure Switch	040050100000-R	040050100000-R	040050100000-R
13	Drain Plate	002060030699	002060022099	002060022099
14	Right Seal Panel	002060020500	002060020500	002060020500
15	Chassis	002060030200	002060020200	002060020200
16	Drain Hose (Inside)	004960010000	004960010000	004960010000
17	Back Panel	002060030101	002060020101	002060020101
18	Compressor	031031040000	031031080000	031031100000
19	Electrical box cover	002060022200	002060022200	002060022200
20	Electrical box	002060022100	002060022100	002060022100
21	Electrical heater bracket	002060030300	002060020400	002060020400
22	Electrical heating element*	z42010030000	042010020000	042010020000
23	Condenser	001010970000	001010750000	001010770000
24	Fan Motor Bracket	002060030400	002060020800	002060020800
25	Left Seal Panel	002060020600	002060020600	002060020600
26	Evaporator	001010960100-R	001010740100-R	001010760100-R
27	PC Board	033060010000	033060010000	033060010000
28	Transformer	036010010000	036010010000	036010010000
29	Terminal Board	039010500000	041012050000	041012050000
30	Compressor capacitor	041020250000	041020450000	041020500000
31	Fan motor capacitor	041010020000	041012050000	041012050000
32	Contactora	/	/	040010020000
33	Draining tube	003991700000	003991700000	003991700000
34	Electronic Expansion Valve	006121000000	006121000000	006121000000
35	High / Low Pressure Valve	006080500000	006080500000	006080500000

**\* For electrical heating element, it's non-standard spare parts.  
Only dehumidifier with extra electric heating function has this spare part inside the machine.**

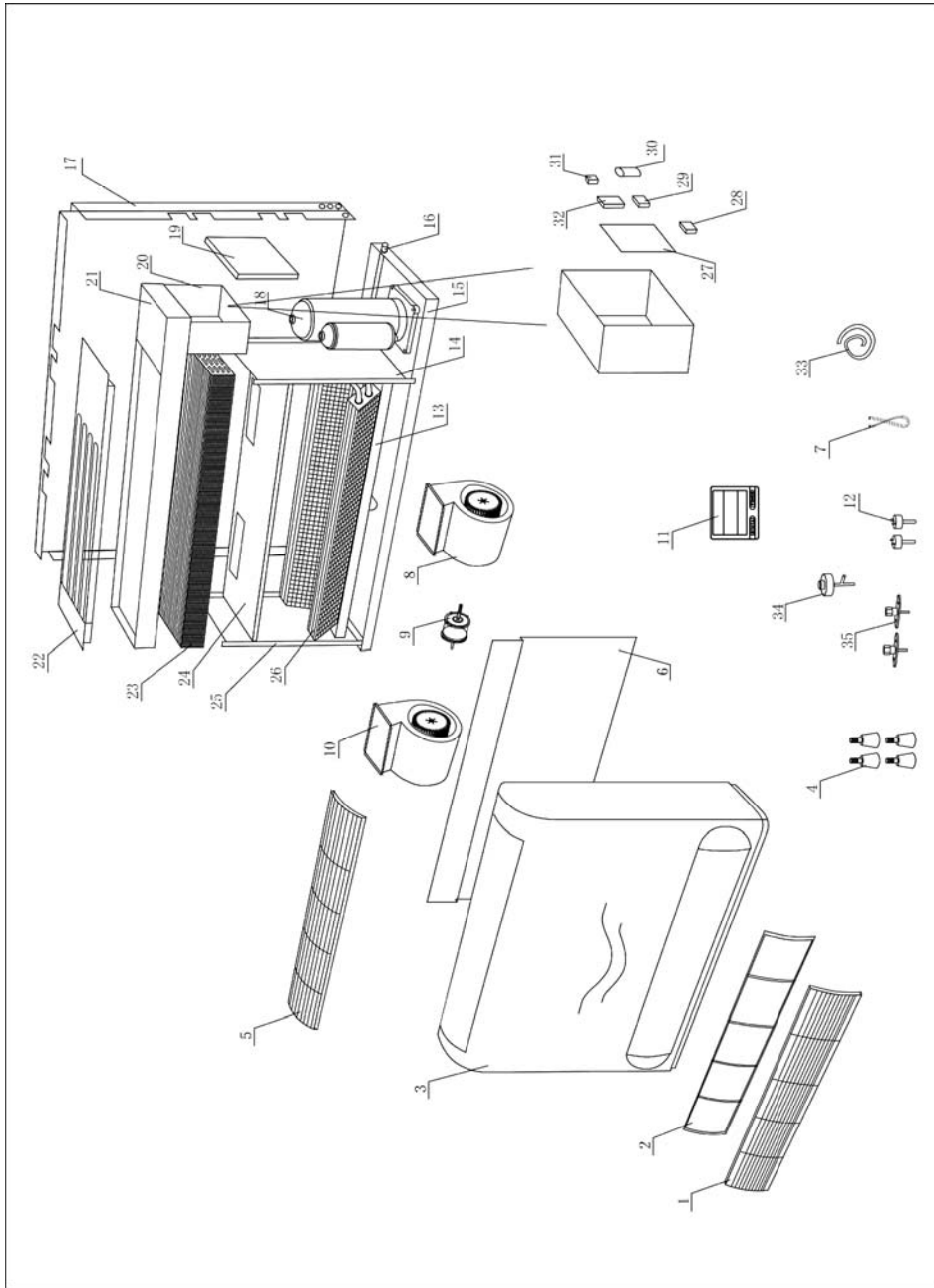

b. PCB layout

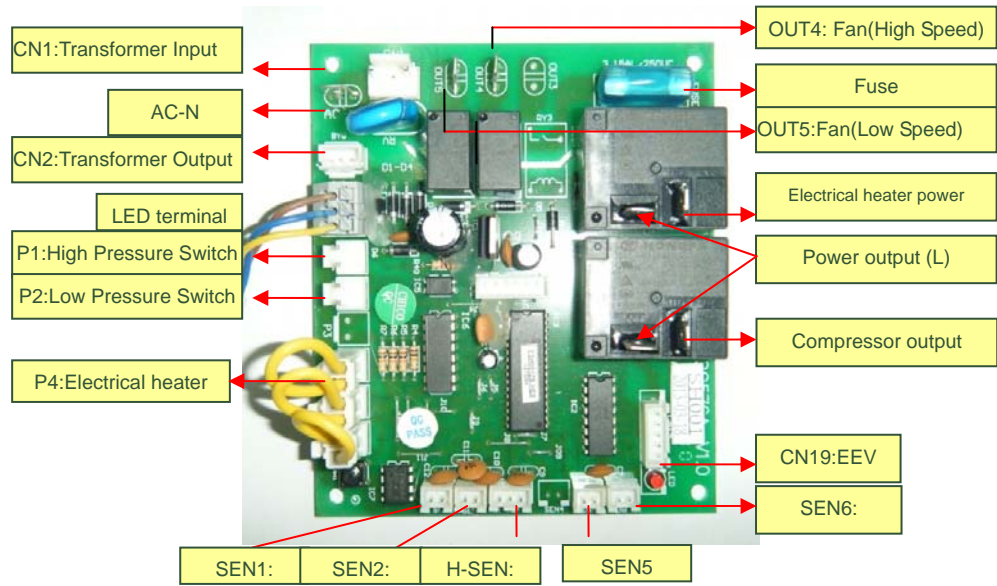

Version: H64B-140715